

RODDING EYES

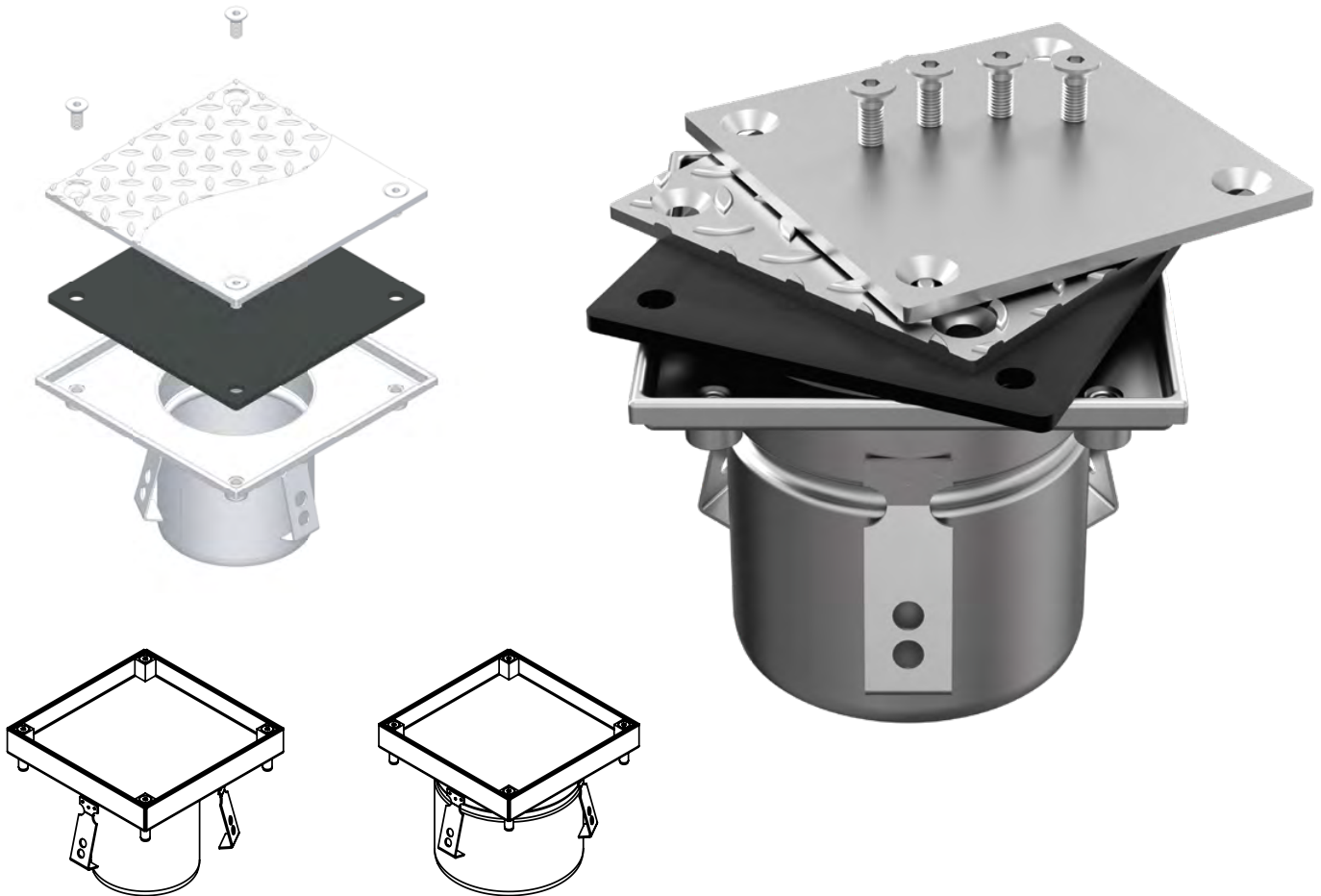

These sewage system elements are widely applied in industrial facilities (chemical, food, pharmaceutical plants etc.). Use of a rodding eye allows quick access to the underfloor area and easy cleaning.

Rodding eyes are made of AISI304 or AISI316 grade steel. Penetration of water is prevented by the seal installed between the bolted cover and the body.

Two types of covers are available:

- **smooth (G),**
- **checker plate (R).**

Edge finish allows for installation in any type of floor.

We offer rodding eyes for sewage pipes of diameters from DN110.

ADVANTAGES OF RODDING EYES

- resistant to corrosion,
- provide a barrier against odours,
- easy installation,
- dimensions of offered rodding eyes are adapted to the sewage system diameter,
- an aesthetically pleasing design element.

INSTALLATION OF RODDING EYES

1. Drain pipe must be connected at an appropriate height.
2. While pouring concrete, the upper part of the rodding eye must be located approximately 1-1.5 [mm] below the floor.

RODDING EYES

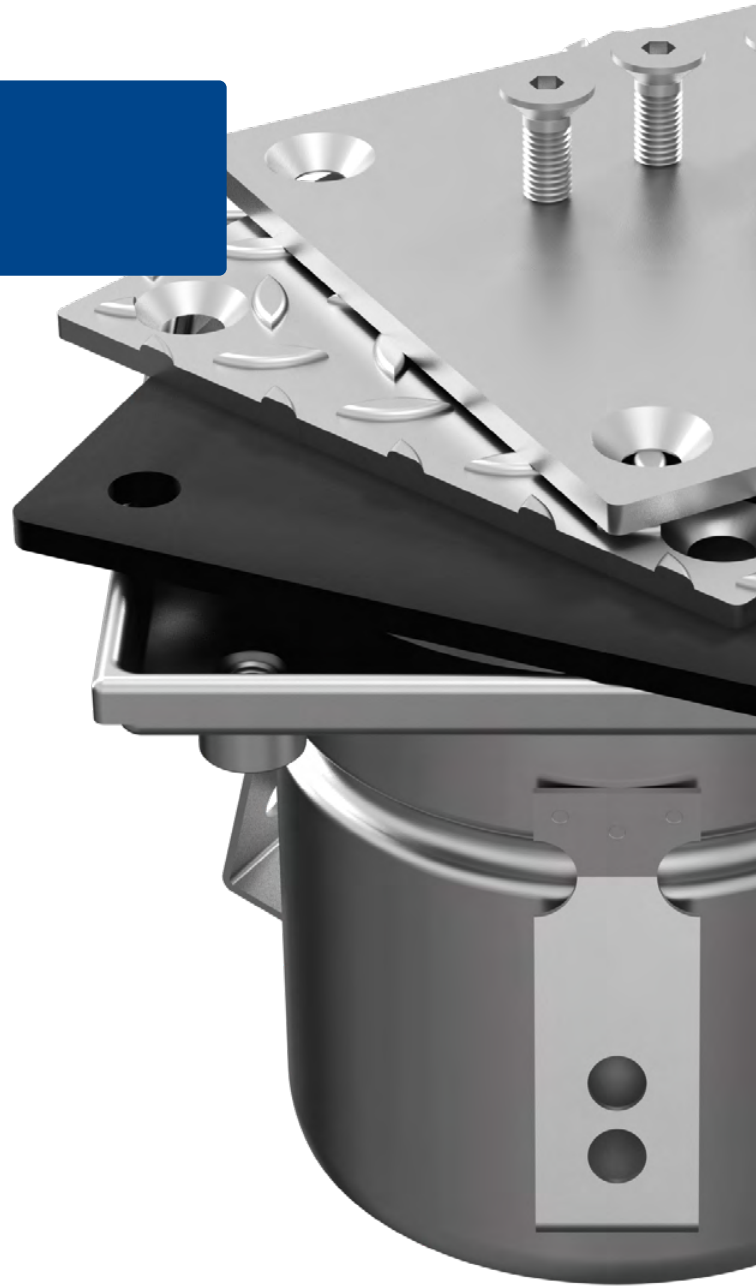

Symbol	Catalogue number.	Dimensions [mm]	
Rw 150/110		DN	110
Catalogue number of complete rodding eye mat. 304 with smooth plate grating	08.050110.53	W	150
Catalogue number of complete rodding eye mat. 304 with checker plate grating	08.050110.54	H	126
Smooth plate grating	11.150141.02		
Checker plate grating	13.150141.02		

Symbol	Catalogue number.	Dimensions [mm]	
Rw 200/110		DN	110
Catalogue number of complete rodding eye mat. 304 with smooth plate grating	08.051110.53	W	200
Catalogue number of complete rodding eye mat. 304 with checker plate grating	08.051110.54	H	127
Smooth plate grating	11.200195.02		
Checker plate grating	13.200195.02		

Symbol	Catalogue number.	Dimensions [mm]	
Rw 200/160		DN	160
Catalogue number of complete rodding eye mat. 304 with smooth plate grating	08.051160.53	W	200
Catalogue number of complete rodding eye mat. 304 with checker plate grating	08.051160.54	H	127
Smooth plate grating	11.200195.02		
Checker plate grating	13.200195.02		

Symbol	Catalogue number.	Dimensions [mm]	
Rw 250/160		DN	160
Catalogue number of complete rodding eye mat. 304 with smooth plate grating	08.052160.53	W	250
Catalogue number of complete rodding eye mat. 304 with checker plate grating	08.052160.54	H	127
Smooth plate grating	11.250245.02		
Checker plate grating	13.250245.02		

Symbol	Catalogue number.	Dimensions [mm]	
Rw 250/200		DN	200
Catalogue number of complete rodding eye mat. 304 with smooth plate grating	08.053200.53	W	300
Catalogue number of complete rodding eye mat. 304 with checker plate grating	08.053200.54	H	127
Smooth plate grating	11.300295.02		
Checker plate grating	13.300295.02		

Symbol	Catalogue number.	Dimensions [mm]	
Rw 300/160		DN	160
Catalogue number of complete rodding eye mat. 304 with smooth plate grating	08.053160.53	W	300
Catalogue number of complete rodding eye mat. 304 with checker plate grating	08.053160.54	H	127
Smooth plate grating	11.300295.02		
Checker plate grating	13.300295.02		

Symbol	Catalogue number.	Dimensions [mm]	
Rw 300/200		DN	200
Catalogue number of complete rodding eye mat. 304 with smooth plate grating	00.053200.53	W	300
Catalogue number of complete rodding eye mat. 304 with checker plate grating	00.053200.54	H	127
Smooth plate grating	11.300295.02		
Checker plate grating	13.300295.02		

RODDING EYES

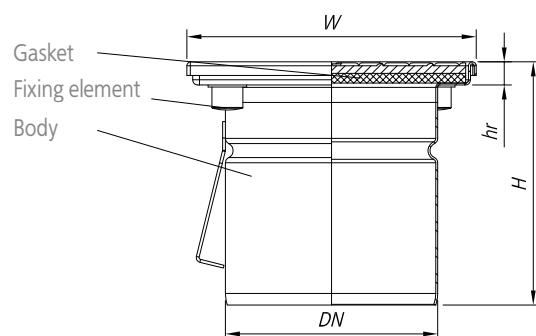

CHECKER PLATE COVER



SMOOTH COVER



ELEMENTS OF RODDING EYE

- body,
- cover,
- fixing screws,
- seal.