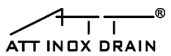

Description:		
Project:	Plate 300x300	
Material:	2,0 mm AISI 304 BRUSHED	
Grating:	-	
Ark./Sheet.:	1/1	
DRAW. NO:		 ATT Sp. z o.o., ul. Albatrosów 16 c, Poland tel. +48 12 290 29 30, att@att.eu, www@att.eu
DJ/200130		