

L=500/1000

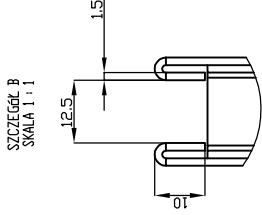

SZCZEGÓŁ B  
SKALA 1:1

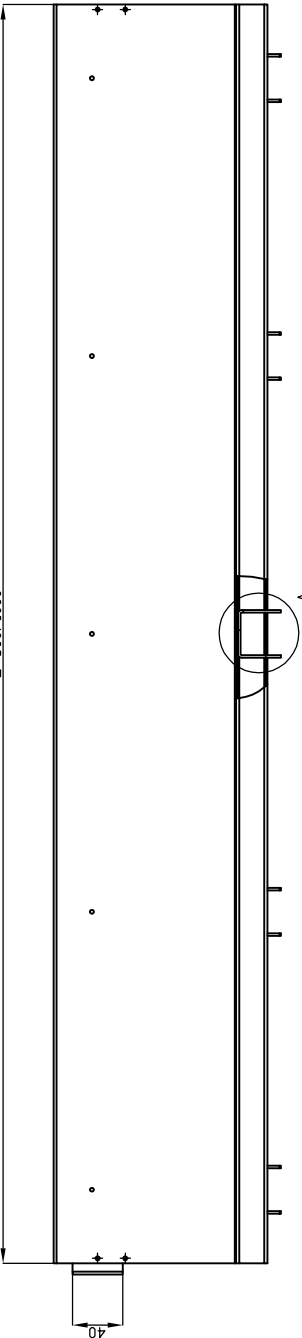
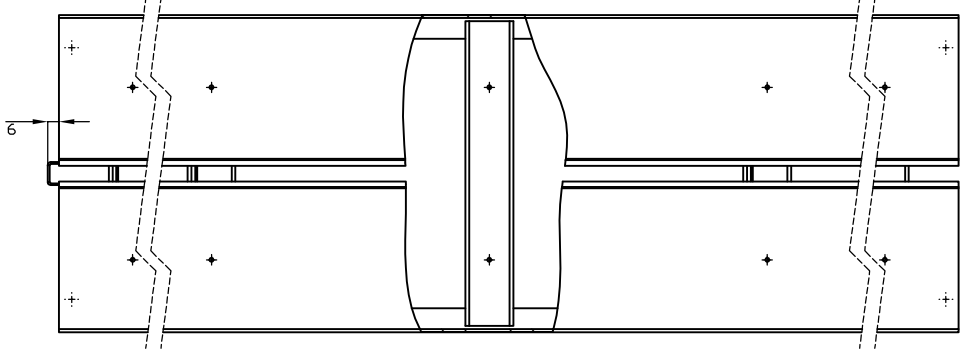
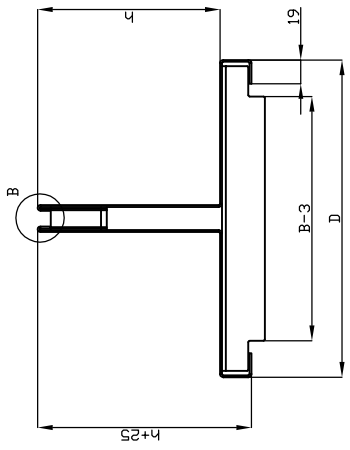
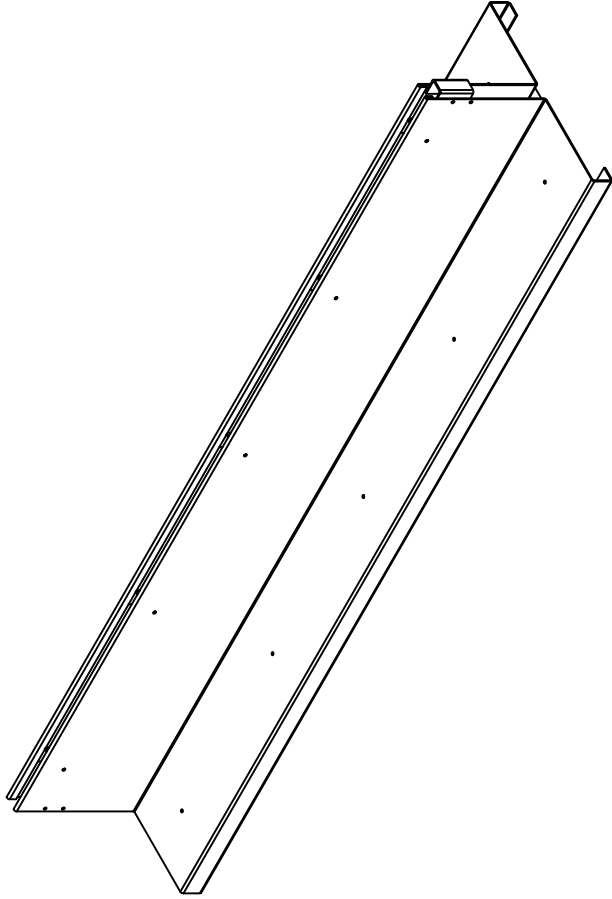
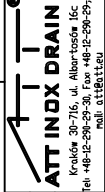

Waga/ Description	Zam. nr./Order no	Project:	Prz.
Firma/Company	R-20-0104	Material:	304
ATT		Ruszt/Grating:	
szt./pcs:	1	Ark./Sheet:	1/1
Dobrym/Outlet type	spadek/slope	RYS.-NR./DRAW.-NO:	
rubber	profile	PG/200227	
gama	plastownik		
 <b>ATT INOX DRAIN</b> Kraków 30-716, ul. Albatrosa 16c Tel: +48-12-699-99-30, Fax: +48-12-699-99-31 mail: att@att.eu			

L=500/1000

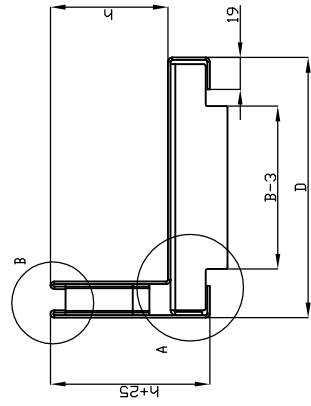
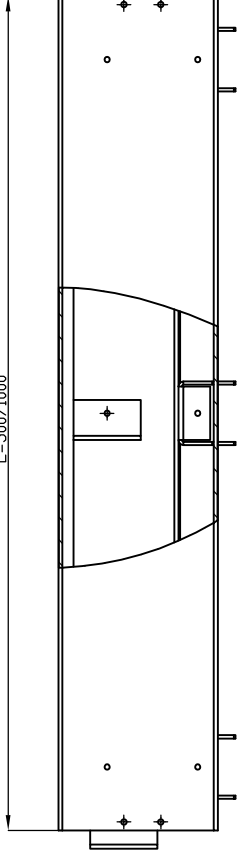

SZCZEGÓŁ B  
SKALA 1 : 1

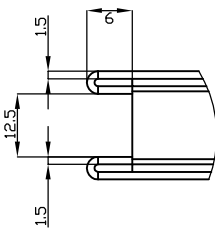

SZCZEGÓŁ A  
SKALA 1 : 1

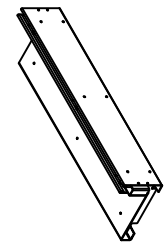
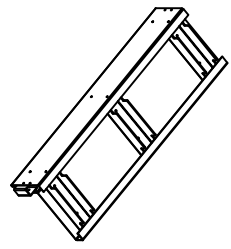
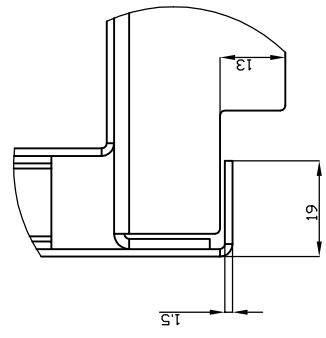

Firma/Company		Zam. nr./Order no		Project:	
ATT		R-20-0104		304	
szt./pcs:		1		Ruszt./Grating	
Dopływ/Dutlet		Spadek/slope		Ark./Sheet:	
rubier		%		1/1	
Wypełn./Backfill:		profile		RYS.-NR./DRAW.-NO:	
beton		plastownik		DW/200227	
				ATT INDEX DRAIN	
				Kraków 30-716, ul. Albatrosa 16c	
				Tel: +48-12-699-99-30, Fax: +48-12-699-99-31	
				mail: a1@att.eu	

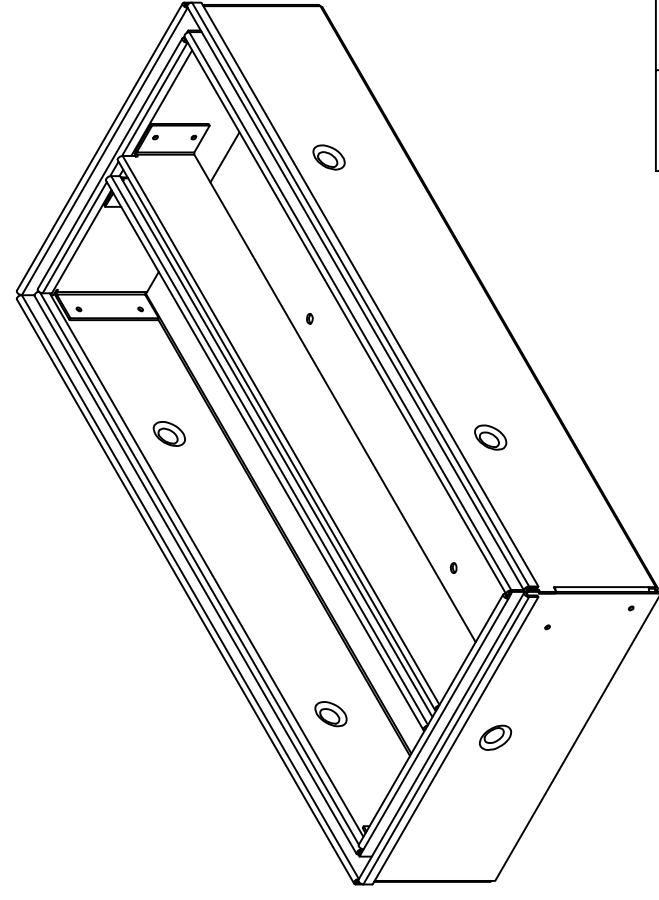
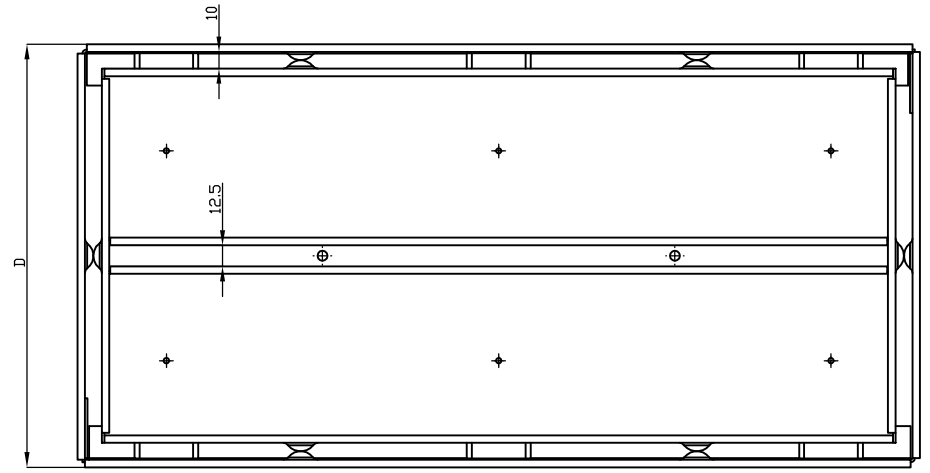
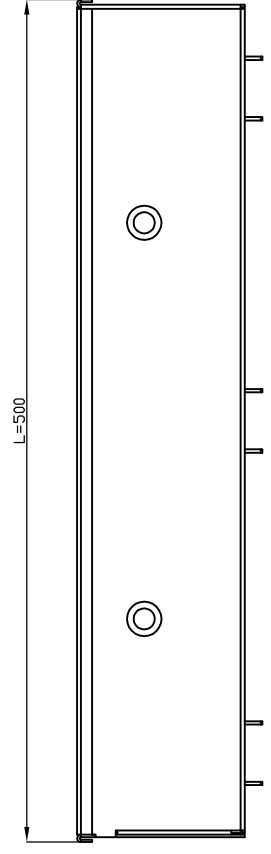
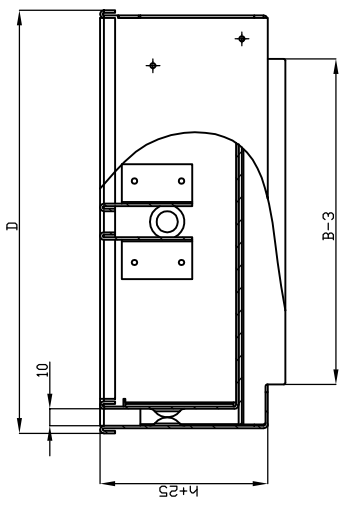

Firma/Company		Zam. nr./Order no		Project:		Waga/Description	
ATT		R-20-0104		ALIS304			
szt./pcs:		1		Ruszt/Grating:		1/1	
Doblym/Durlet type		Spadek/slope		RYS-NR/DRAW-NR		PC/200227	
Wypełn./Backfill:		profil		Flak		Płaskownik	
						ATT INOX DRAIN	
						Kraków 30-716, ul. Albatrosa 16c	
						Tel: +48-12-699-99-30, Fax: +48-12-699-99-31	
						mail: a1@att.eu	

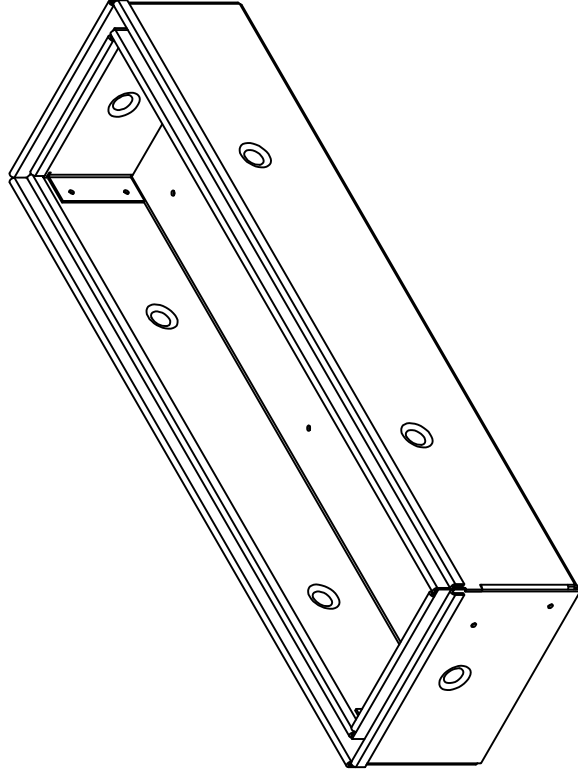
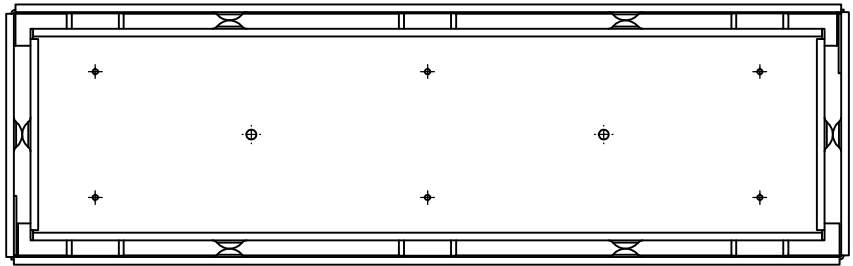
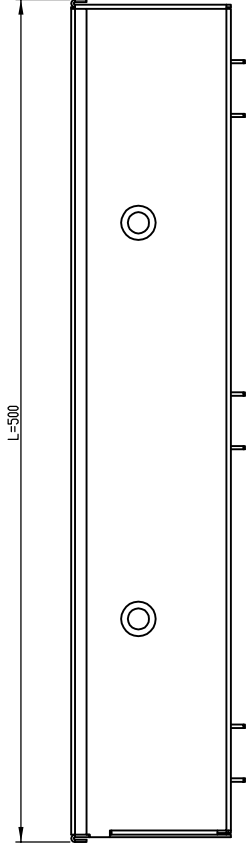
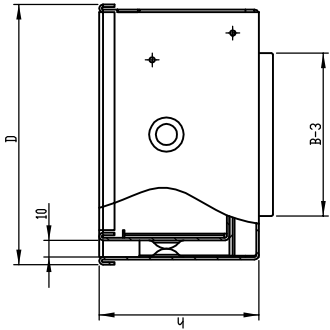

Firma/Company		Zam. nr./Order no	Project:	
ATT		R-20-0104	304	
szt./pcs:	1	Spadek/slope	‰	1/1
Doblyw/Durlet type		RYS.-NR./DRAW.-NO:		
Wypein/Backfill:		PC/200228		
rubber		Flak		
gum		plastownik		
profile		plastownik		
Uwagi/Description		ATT INDEX DRAIN		
		Kraków 30-716, ul. Albatrosa 16c Tel: +48-12-699-99-30, Fax: +48-12-699-99-31 mail: a1@att.eu		